



BITZER Output data

Created on : 25.01.2015 10:07:45



Table of content

Project survey.....	3
Compressor Selection: Semi-hermetic Reciprocating Compressors.....	4
Technical Data: 4GE-23Y.....	5
Semi-hermetic Reciprocating Compressors.....	6
Horizontal receivers.....	7
Liquid receiver.....	8



Project survey

Selected compressors

Semi-hermetic Reciprocating Compressors

1x 4GE-23Y

Chosen accessory

[Horizontal receivers](#)



Compressor Selection: Semi-hermetic Reciprocating Compressors

Input Values

Compressor model Mode	4GE-23Y Refrigeration and Air conditioning	Suction gas temperature Operating mode	20,00 °C Auto
Refrigerant Reference temperature Liq. subc. (in condenser)	R404A Dew point temp. 0 K	Power supply Capacity Control Useful superheat	400V-3-50Hz 100% 100%

Result

Q [W]	Cooling capacity	COP [-]	COP/EER
Q* [W]	Cooling capacity *	COP* [-]	COP/EER *
P [kW]	Power input	m [kg/h]	Mass flow
I [A]	Current	Op.	Operating mode
Qc [W]	Condenser Capacity	th [°C]	Discharge gas temp. w/o cooling

tc	to	10°C	5°C	0°C	-5°C	-10°C	-15°C	-20°C	-25°C
30°C	Q [W]	--	--	83782	69859	57789	47352	38363	30659
	Q* [W]	--	--	83782	69859	57789	47352	38363	30659
	P [kW]			18,72	17,88	16,84	15,63	14,30	12,88
	I [A]			31,4	30,0	28,4	26,5	24,5	22,4
	Qc [W]			102501	87740	74628	62984	52661	43535
	COP [-]			4,48	3,91	3,43	3,03	2,68	2,38
	COP* [-]			4,48	3,91	3,43	3,03	2,68	2,38
	m [kg/h]			2130	1755	1437	1168	940	747
	Op.			Standard	Standard	Standard	Standard	Standard	Standard
	th [°C]			63,1	69,2	75,5	82,2	89,2	96,7
40°C	Q [W]	--	--	71791	59777	49343	40313	32535	25873
	Q* [W]	--	--	71791	59777	49343	40313	32535	25873
	P [kW]			22,1	20,7	19,13	17,44	15,68	13,88
	I [A]			36,9	34,5	32,0	29,3	26,6	23,9
	Qc [W]			93939	80493	68477	57754	48211	39751
	COP [-]			3,24	2,89	2,58	2,31	2,08	1,86
	COP* [-]			3,24	2,89	2,58	2,31	2,08	1,86
	m [kg/h]			2059	1692	1381	1118	895	707
	Op.			Standard	Standard	Standard	Standard	Standard	Standard
	th [°C]			74,3	80,4	86,7	93,4	100,4	107,9
50°C	Q [W]	--	--	59259	49277	40585	33051	26560	21004
	Q* [W]	--	--	59259	49277	40585	33051	26560	21004
	P [kW]			25,1	23,1	21,0	18,88	16,72	14,58
	I [A]			41,7	38,4	35,1	31,6	28,2	24,9
	Qc [W]			84368	72393	61613	51936	43283	35587
	COP [-]			2,36	2,13	1,93	1,75	1,59	1,44
	COP* [-]			2,36	2,13	1,93	1,75	1,59	1,44
	m [kg/h]			1974	1616	1314	1059	843	661
	Op.			Standard	Standard	Standard	Standard	Standard	Standard
	th [°C]			85,7	91,8	98,1	104,8	111,8	119,4

-- No calculation possible (see message in single point selection)

*According to EN12900 (20°C suction gas temp., 0K liquid subcooling)

Application Limits 100%

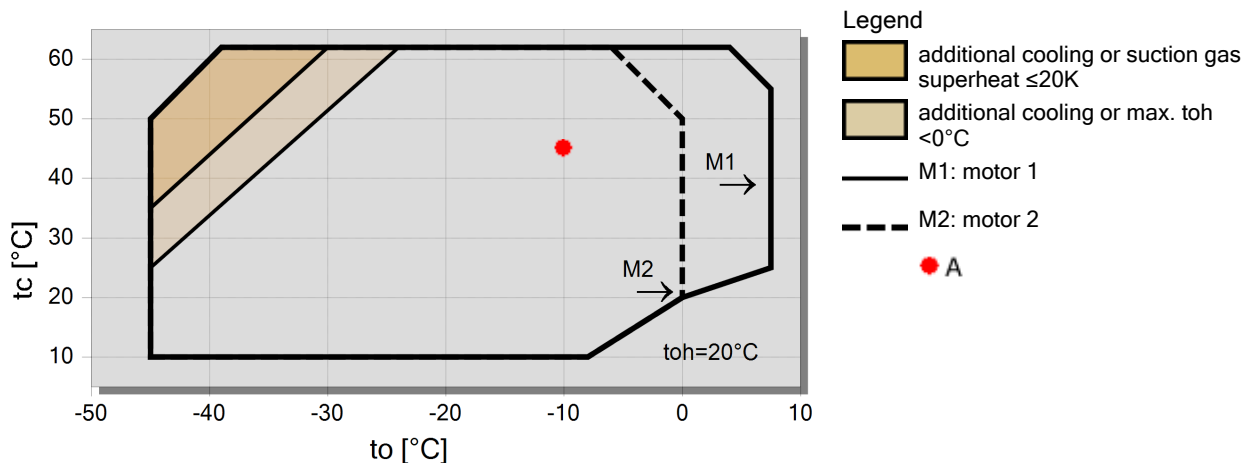



Technical Data: 4GE-23Y

Dimensions and Connections

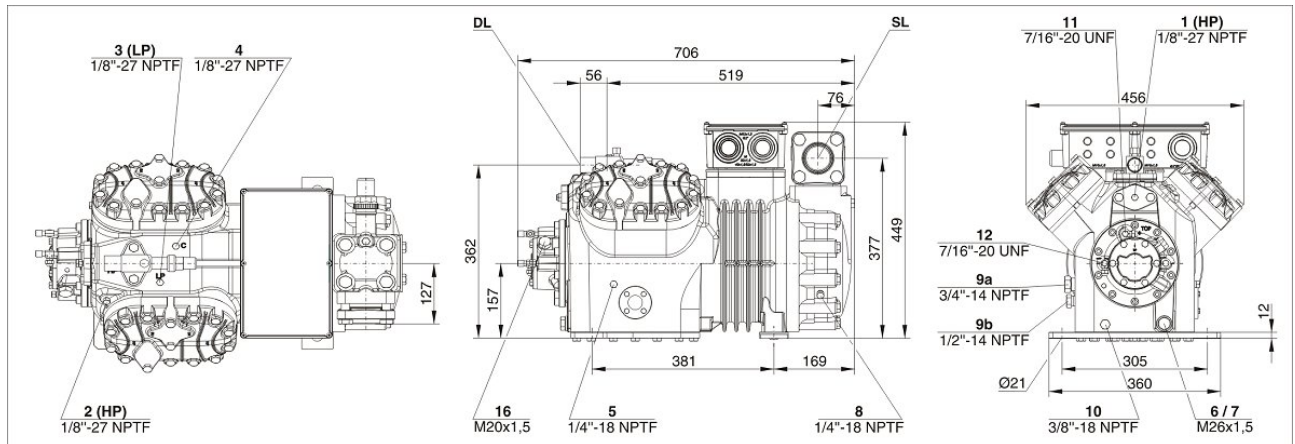

Technical Data

Technical Data

Displacement (1450 RPM 50Hz)	84,5 m ³ /h
Displacement (1750 RPM 60Hz)	101,98 m ³ /h
No. of cylinder x bore x stroke	4 x 75 mm x 55 mm
Weight	192 kg
Max. pressure (LP/HP)	19 / 32 bar
Connection suction line	54 mm - 2 1/8"
Connection discharge line	28 mm - 1 1/8"
Oil type R134a/R407C/R404A/R507A/R407A/R407F	BSE32(Standard) / R134a tc>70°C: BSE55 (Option)
Oil type R22 (R12/R502)	B5.2(Option)

Motor data

Motor version	2
Motor voltage (more on request)	380-420V PW-3-50Hz
Max operating current	43.9 A
Winding ratio	50/50
Starting current (Rotor locked)	97.0 A Y / 158.0 A YY
Max. Power input	27,0 kW

Extent of delivery (Standard)

Motor protection	SE-B2
Enclosure class	IP54 (Standard), IP66 (Option)
Vibration dampers	Standard
Oil charge	4,50 dm ³

Available Options

Discharge gas temperature sensor	Option
Start unloading	Option
Capacity control	100-50% (Option)
Capacity Control - infinite	100-10% (Option)
Additional fan	Option
CIC System	Option
Oil service valve	Option
Crankcase heater	140 W (Option)
Oil pressure monitoring	MP54 (Option), Delta-PII

Sound measurement

Sound power level (-10°C / 45°C)	81,0 dB(A) @50Hz
Sound power level (-35°C / 40°C)	86,5 dB(A) @50Hz
Sound pressure level @ 1m (-10°C / 45°C)	73 dB(A) @50Hz
Sound pressure level @ 1m (-35°C / 40°C)	78,5 dB(A) @50Hz
Sound power level (-10°C / 45°C) R134a	79 dB(A) @50Hz
Sound pressure level @ 1m (-10°C / 45°C) R134a	71 dB(A) @50Hz



Semi-hermetic Reciprocating Compressors

Motor 1 = e.g. 4TES-12 (4TCS-12.2) with 12"HP", primary for air-conditioning (e.g. R22,R407C) and air-conditioning with R134a at high ambient temperatures

Motor 2 = e.g. 4TES-9 (4TCS-8.2) with 8"HP", universal Motor for medium and low temperature application (e.g. R404A, R507A, R407A, R407F) and air-conditioning with R134a.

Motor 3 = e.g. 4TES-8, for medium temperature applications and R134a

For more information concerning the application range use the "Limits" button.

Operation modes 4VES-7 (4VCS-6.2) to 6FE-44 (6F-40.2) and 44JE-30 (44J-26.2) to 66FE-88 (66F-80.2) with R407F/R407A/R22:

CIC = liquid injection with low temperature application, suction gas cooled motor

ASERCOM certified performance data:

The Association of European Refrigeration Component Manufacturers has implemented a procedure of certifying performance data. The high standard of these certifications is assured by:

-- plausibility tests of the data performed by experts

-- regular measurements at independent institutes

These high efforts result in the fact that only a limited number of compressors can be submitted. Due to this not all BITZER compressors are certified until now.

Performance data of compressors which fulfil the strict requirements may carry the label "ASERCOM certified". In this software you will find the label at the respective compressors on the right side below the field "result" or in the print out of the performance data. All certified compressors and further information are listed on the homepage of ASERCOM (www.ASERCOM.org).

Condensing capacity:

The condensing capacity can be calculated with or without heat rejection. This option can be set in the menu PROGRAM/OPTIONS. The heat rejection is constantly 5% of the power consumption. The condensing capacity is to be found in the line Condensing cap. (with HR) resp. Condensing capacity.

Data for sound emission:

Data based on 50 HZ application (IP-units 60Hz) and R404A if not declared.

Sound pressure level: values based on free field area conditions with hemispherical sound emission in 1 meter distance.

General remarks regarding sound data:

Listed sound data were measured under testing conditions in our laboratory. For this purpose the free-standing test sample is mounted on a solid foundation plate and the pipework is connected vibration-free to the largest extend possible. Suction and discharge lines are fixed in a flexible configuration, such that a transmission of vibrations to the environment can be largely excluded. In real installations considerable differences might be observed, compared to the measurements in the laboratory. The airborne sound emitted by the compressor can be reflected from surfaces of the system and this may increase the airborne sound level measured close to the compressor. Vibrations caused by the compressor are also transferred to the system by the compressor feet and piping depending on the damping ratio of the fixings. Thus, the vibrations can induce other components to such an extent that these components contribute to an increase in airborne sound emission. If required, the transfer of vibrations to the system can be minimized by suitable fixing and damping elements.

Legend of connection positions according to "Dimensions":

- 1 High pressure connection (HP)
- 2 Discharge gas temperature sensor (HP)
- 3 Low pressure connection (LP)
- 4 CIC system: spray nozzle (LP)
- 4b CIC sensor
- 5 Oil fill plug
- 6 Oil drain (magnetic screw)
- 7 Oil filter
- 8 Oil return (oil separator)
- 9 Oil and gas equalization (parallel operation)
- 9a Gas equalization (parallel operation)
- 9b Oil equalization (parallel operation)
- 10 Crankcase heater
- 11 Oil pressure connection +
- 12 Oil pressure connection -
- 13 Cooling water connection
- 16 Connection for differential oil pressure switch "Delta-P"



Horizontal receivers

Input Values

Common	Yes
Auto	
Operating point	Auto

Operating Points

	A
to [°C]	-10
tc [°C]	45

Result

#1: **Err_996998** [996998]



Liquid receiver

Selection of the receivers:

1) "Approx. according to cooling capacity":

The receiver volume is determined by the design of the unit, the operating mode and the function of the receiver (receiving the complete refrigerant charge in the receiver or only compensating capacity variations). When selected via cooling capacity, an approximate selection of the receiver is obtained.

Receivers in systems with long pipelines, winter control or in very compact systems should be selected according to method 2).

2) "According to refrigerant charge in the receiver":

The calculation is made on the basis of the specified refrigerant charge. The receiver volume is determined at 20°C and at a maximum filling charge of 95% of the possible receiver content.

Compressor units equipped with receiver

The BITZER range of products comprises compressor units with horizontal receivers. In the output window of the accessories these units, which are included in the standard delivery, are marked with "mounted" in the compressor unit line. Units that can be mounted, but are not included in the Bitzer delivery program, are marked with "single parts". Units in which the compressor does not fit onto the receiver are marked with "--".

Legend of connection positions according to "Dimensions":